

Gerber Innovations FT Laser™



Site Preparation & Installation Manual

Dear Prospective Customer,

Thank you for your interest in Gerber equipment. We are pleased to provide you this facilities site preparation document. Below you will find electrical, pneumatic and other facilities specifications that you are required to provide to ensure the successful installation, training and operation of the equipment. Please review these specifications and confirm in writing that all of these requirements are already met and/ or will be met PRIOR to the arrival of a Gerber technician to perform installation of the equipment.

Thank you in advance for your cooperation. Your attention to the detailed facilities requirements below will allow our technicians to focus their time on the installation of your new equipment and training your staff to become proficient with its operation.

To make the process as easy as possible, please review and implement the facilities requirements below and when completed, you can use the google forms link below or email to fill out and sign your site preparation confirmation.

Facilities Site Preparation Check list

Customer Name: _____

Name of Customer Representative completing the form: _____

Install Location: _____

Please put a check mark in the appropriate column	Yes	No
<i>Electrical Requirements:</i>		
PRC laser – 460VAC±, 60 Hz, 3 phase, 40 amp phase PRC laser – 380VAC±, 50 Hz, 3 phase, 50 amp phase		
Rofin laser – 400/ 480VAC±, 50/ 60Hz, 3 phase, 50 amp phase Rofin laser – 380VAC±, 50 Hz, 3 phase, 60 amp phase		
Chiller – 460VAC±, 60Hz, 3 phase, 29 amp phase Chiller - 380VAC±, 50 Hz, 3 phase, 35 amp phase		
Exhaust Blower – 208-230/ 460±, 60Hz, 3 phase, 14.2-12.8/ 6.4 amp phase (the motor starter for the exhaust blower is supplied by the Customer)		
FT table – 208/ 240V± 5%, 50/ 60Hz, 1 phase, 20 amp		
Computer & Monitor/ Air Dryer/ Vacuum Cleaner – 120±, 60Hz, 1 phase, 20 amp, 4 outlets		
<i>Pneumatic Requirements:</i>		
PRC pneumatic supply – Pressure to the laser head must be 4 to 6.9 bar (60 to 100 PSI) in order to satisfy the pressure switch. The flow rate is 9.2 L/ m (19 ft ³ / hour)		
PRC pneumatic quality – helium (He) 99.995% purity welding grade, Nitrogen (N ₂) 99.5% purity welding grade, Carbon Dioxide (CO ₂) 99.5% purity welding grade, dew point not above 40°F (4.5°C)		
Rofin pneumatic supply – Pressure to the laser head must be ≥3.5 bar (~50 PSI) in order to satisfy the pressure switch. The flow rate is ≥4.0 L/ m (8.5 ft ³ / hour)		
Rofin pneumatic quality – oil ≤ 0.005mg/ m ³ (3.12x10 ⁻¹⁰ lbs/ ft ³), water ≤ 0.05g/ m ³ (3.12x10 ⁻⁶ lbs/ ft ³), filter pore size ≤ 0.05µM (1.97µ in), relative air humidity 50% at 40C, 90% at 20C (air temperature must be above the dew point to prevent condensation from forming).		
Rofin Purge air requirements – the system requires Nitrogen or Compressed Dry air (CDA) in order to properly purge the beam forming optics.		
Laser Gas bottle and regulator requirements – customer is required to provide bottled laser gases and regulator.		

Chiller Coolant – Distilled water and coolant fluid is required to operate the chiller. The customer is required to provide these items. See paragraph on Coolant Fluid.		
Hard Piping for Chiller – If chiller hard piping is required. Please see section for Hard Piping.		
Professional riggers are required to handle the equipment safely. Please arrange to have riggers remove the equipment from the truck and position the equipment in your facility. See Appendix B for crate information.		
Please sign your name below to acknowledge you understand all of the above requirements. _____		
For Gerber use only: Zone Manager _____ Zone Admin _____ Date Sent: _____		

Please send this completed form back to Gerber. You can either use Google forms to complete the form, or complete this version above and email.

1. USING GOOGLE FORMS

Please use the link below to open the check list in google forms. Please open a web browser prior to clicking on the link.

[FT Laser Check List](#)

2. USING EMAIL

Use the email address for Gerber Innovations Customer Solutions Center at gicsc@gerberscientific.com.

Upon receipt of this completed form, Gerber will schedule the installation and training.

Chapter One: Introduction

In this manual

This manual is divided into the following sections:

Chapter One: Introduction

Chapter Two: Site Preparation and Installation

Appendix A: Typical floor plans for FT1800 and FT2400 and both PRC Laser and Rofin Laser

Appendix B: Shipping Crates for FT1800 and FT 2400

Conventions used in this manual



WARNING: A warning statement contains information which, if not followed, could result in electrical shock hazard.



CAUTION: A caution statement contains information which, if not followed, could result in personal injury or equipment damage.



NOTE: A note contains important information that affects the successful completion of a task.



TIP: A tip contains a suggestion to make your task easier or to remind you of something that may appear elsewhere in the booklet.

Technical Support

If you have questions regarding using, maintaining, or troubleshooting the Fastrack Laser please contact Gerber Innovations.

	800-400-3458 (Toll free in USA) 860-871-3757 (Outside the USA)
	gicsc@gerberscientific.com
	www.gerberinnovations.com

Chapter Two:

Site Preparation and Installation

Prior to the arrival of your machine and in addition to the facilities site preparation checklist requirements, there are certain things you can have prepared to facilitate a quick and smooth installation. The following information will guide you.

Floor Plan

Refer to Appendix A – FT1800 or FT2400 Floor plans for the dimensions of the machine and necessary clearance.

Preparation

- ◆ Allow sufficient room for operator access and work handling.
- ◆ Exhaust, electrical and pneumatic connections are most conveniently attached at the rear of the machine.
- ◆ Clean and wax the floor if appropriate. To avoid static electricity, which can interfere with computer operations, carpets are not recommended.
- ◆ Isolation of machine by partitions or windowed walls should be considered, as the machine generates noise and fumes and contains a class IV laser device.
- ◆ Floor stability is important due to the precision requirements of a die board. If there is other equipment in the building that generates vibration in the floor, such as presses or fork truck traffic, you will need to install the laser in a way that isolates it from these vibration sources.

Riggers

It is the customer's responsibility to make arrangements to hire local riggers to assist in the unloading of the FT Laser off the truck and moved into the proper location within your plant.

External Inputs and Connections

Exhaust Blower

Prior to delivery of your machine, the exhaust blower should be shipped to you. The blower is usually installed on the roof and as close as is practical to the laser. See Figure 1 for dimensions.

The exhaust blower ships fully assembled.

The blower moves a high volume of air, on the order of 2200 cfm (62.3 cmm). You should check with your HVAC supplier as to the impact this will have on your environmental controls.

Exhaust Ducting

Ten inch sheet metal ducting must be provided between the inlet of the blower and above the fast track laser system. The use of elbows should be kept to a minimum. There are two 5" (12.7 cm) connections on the front and rear of the fast track FT2400 (one on the rear of the FT 1800). From these connections; a 5" (12.7 cm) flexible hose is used to connect to the customer supplied duct work. Gerber Innovations supplies 50' (15.24 m) of this hose, so the connections must be 8' (2.44 m) minimum from the top of the machine. Next to the middle 5" (12.7 cm) connection there should be a 2" (5.1 cm) connection for the nozzle exhaust hose. See Appendix C – Exhaust ducting for a drawing of a typical installation.

Electrical



Note: Contact customer service to be sure the exhaust blower is shipped early.

Please refer to the site preparation checklist for the electrical specifications for the exhaust blower motor. The motor starter is customer-supplied and must be wired in conformance with local electrical codes. The start/ stop switch should be mounted near to the front left of the Laser System.

Automatic Blower Operation

If you would like to use a magnetic starter as opposed to a manual starter, provision is made inside the Gerber Innovations controller to pilot the starter. We provide a normally open set of relay contacts and two terminals for field hookup. The exhaust can then be automatically controlled by the cutting system. The contact is rated for 110V or lower.

Chip extractor/vacuum

Gerber does not provide a vacuum cleaner for the drill/ router chip extraction. The customer must provide one.

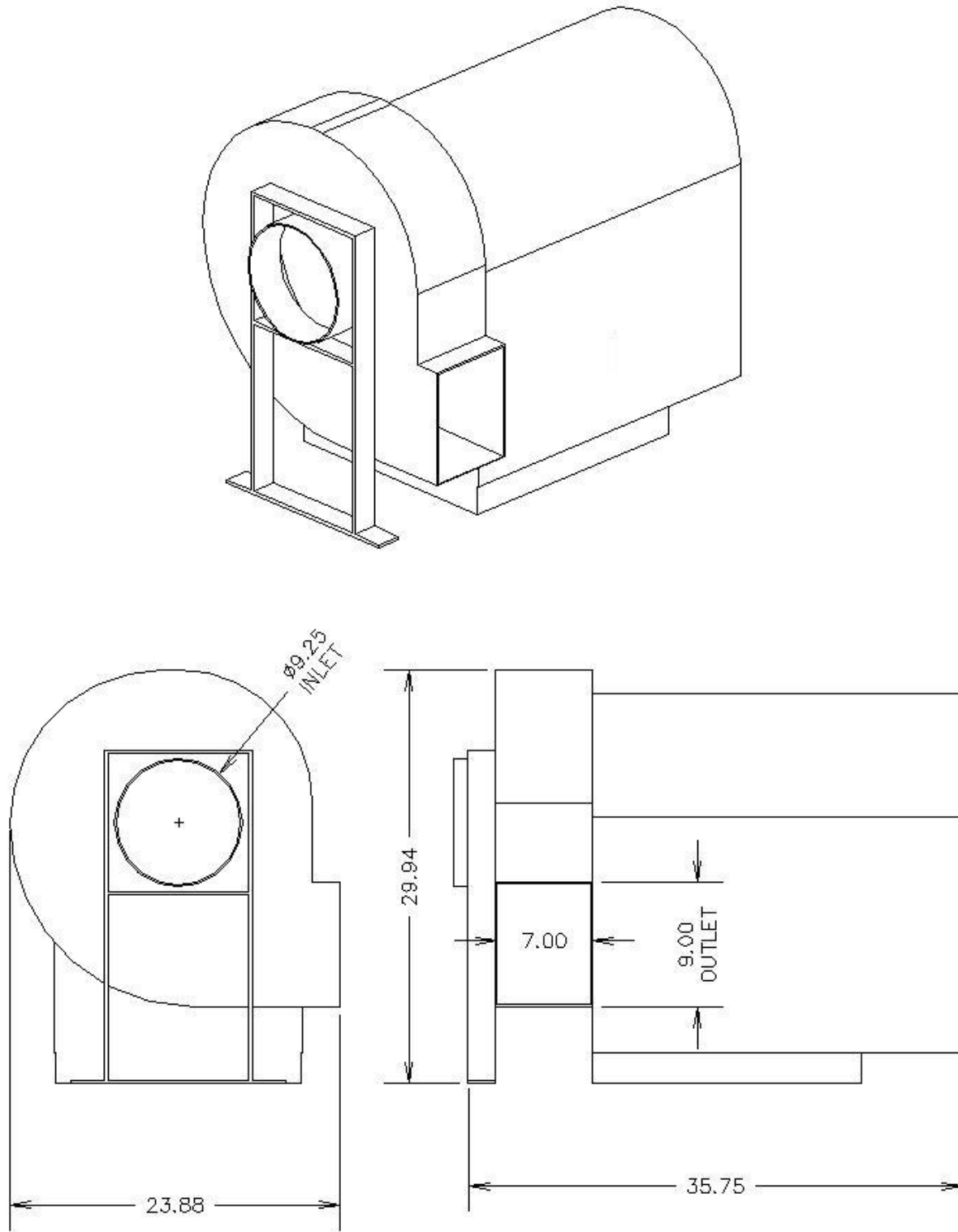

Figure 1 – Exhaust Blower

(All dimensions shown in this diagram are in inches)

Chiller

The Chiller is required for the proper operation of the laser. It generates heat and noise which usually determines where it will be located and how it will be vented. The following list contains points of consideration.

- ◆ Due to the heat generated you may want to vent the chiller out of the room.
- ◆ The maximum length of piping between the laser and chiller is 75 feet.
- ◆ The Laser includes 50' (15.2 m) of flexible hose for connecting to the chiller or hard piping. The hose is 1½" (3.5 cm) ID.
- ◆ It is recommended to have the chiller visible from the operator's position on the laser system. This makes turning it on and off convenient and allows monitoring of the set-point and any fault conditions.
- ◆ The chiller is designed for an ambient temperature of 50 – 104° F (10 - 40° C). Please consult Gerber Innovations if your expected ambient temperature is outside this range.

Hard Piping

If you plan on installing hard piping from the chiller refer to the following points of consideration.

- ◆ The piping should have a pressure rating of 100 PSI and should be copper, schedule 80PVC or stainless steel. No other materials are allowed.
- ◆ The chiller has 1½" (38.1 mm) NPTF fittings for inlet and outlet.
- ◆ The piping should be 1½" (3.5 cm) and have a minimum of elbows. Sweep elbows are recommended if more than 2 bends are required.
- ◆ Ball valve shutoffs should be provided at the end of the run. Both valves should terminate with a 1½" (3.5 cm) NPTF connection for the Gerber Innovations supplied hose barbs.
- ◆ As the water temperature is 59°F (15° C), the pipes should be insulated to minimize sweating and to maintain the temperature.
- ◆ Hard piping should be installed before the installation date of the laser system.

Electrical

Please refer to the site preparation checklist for the electrical specifications for the chiller.

Coolant Fluid

The coolant is not shipped with the laser. The chiller has a capacity of 70 gallons (265 L). To calculate the total fluid capacity of your system add 1 gallon every 10 feet (1 liter for every 80 cm) of piping required. The total volume consists of 60% distilled water and 40% Ethylene Glycol. Dowtherm SR-1 or Dowtherm 4000 can be used. Please note that Dowfrost, (propylene glycol), may also be used and is more environmentally friendly in terms of disposal restrictions. Contact Dow chemical at 1-800-447-4369 in the U.S. for specifications and a local distributor near you. Distilled water may be purchased from your local bottled water company.



CAUTION: Do not use Automotive Type Anti-freeze

A Gerber laser system includes either a Fast Axial Flow laser manufactured by PRC or a Slab laser manufactured by Rofin. Please see below for information on each of these lasers.

PRC Laser Services

The laser system requires bottled gas, electrical hookups, clean dew point controlled air and chiller connections.

Laser Gases

The laser control cabinet has connections for the 3 gases. The bottles should be located where they can be checked periodically. The connections in the control cabinet are for 5/ 16" (0.79 cm) OD flexible tubing. Please refer to the site preparation checklist for the laser gas bottle requirements.

- ◆ Two stage regulators are required with the output set for 60-80PSI. They should be terminated with a 1/ 4" MNPT fitting.
- ◆ There should be two tanks of each gas and be chained or secured to a wall.
- ◆ Gases and regulators are not provided by Gerber Innovation and must be in place by the date of install.

Electrical

Please refer to the site preparation checklist for the electrical specifications for the laser.

Rofin Laser Services

Please refer to the site preparation checklist for the electrical specifications for the laser.

The purge gas or purge air which is used to flush the laser beam telescope must correspond to these specifications. A separate air dryer / air filter system is required since factory air alone cannot satisfy the above specifications



Note: The Air dryer that is provided by Gerber is NOT sufficient to use for the purge air on a Rofin laser. A separate dryer must be purchased.

Shipping and Handling

Access

During installation, large machine parts will need to be moved into final position. Any large objects in the work area should be moved out of the way prior to installation.

Arrival

Refer to Appendix C – Shipping Crates for dimensions of the shipping crates.



Note: The exhaust blower is not listed and is usually shipped early.

Loading Dock

The availability of a loading dock will determine what type of truck is used. Please inform Gerber Innovations of this in advance of installation.

Fork Lift

A forklift is necessary to lift the Laser onto the stand. The rigger should bring his own lift and perform this work, not the customer.

Uncrating

Please wait for a Gerber Innovations service person before uncrating.

Other considerations

Please review the safety information as stated in the Laser Installation guide

Tools

When installing the machine, Gerber Innovations personnel will need access to the following:

◆ Pry bar	◆ 3/ 8" reversible/ variable speed pistol drill
◆ Vacuum cleaner	◆ Fantastic or another general purpose cleaner
◆ Extension cord	◆ Spray can of 10-weight oil
◆ Claw hammer	◆ Hammer drill and bits for installing floor anchors
◆ Cloth rags	



WARNING! This equipment utilizes a Class IV laser and appropriate safeguards associated with safe laser operation should be followed. Further information can be obtained via the Occupational Safety and Health Administration's (or OSHA's) Technical Manual (TED 01-00-015) and through the Laser Safety Institute of America (<http://www.laserinstitute.org/>). In addition, it may be advisable or required to designate a Laser Safety Officer (LSO) to ensure continued and safe operation of the laser.

Appendix A: FT1800 – Typical Floor Plan

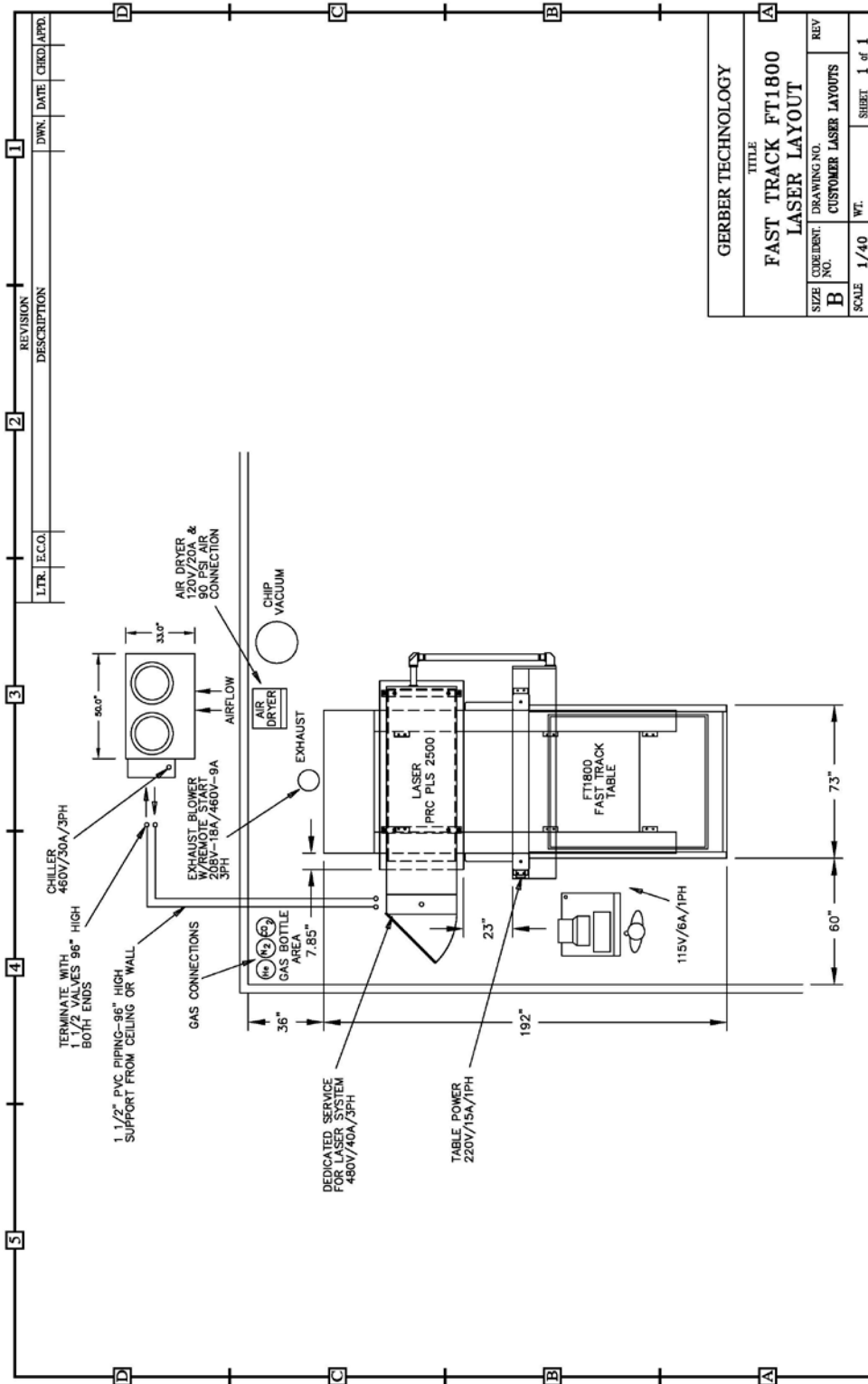

GERBER TECHNOLOGY	
TITLE FAST TRACK FT1800 LASER LAYOUT	
SIZE B	REV 1
CUSTOMER NO. CUSTOMER LASER LAYOUTS	DRAWING NO.
SCALE 1/40	WT. SHEET 1 of 1

Appendix A: FT2400 – Typical Floor Plan

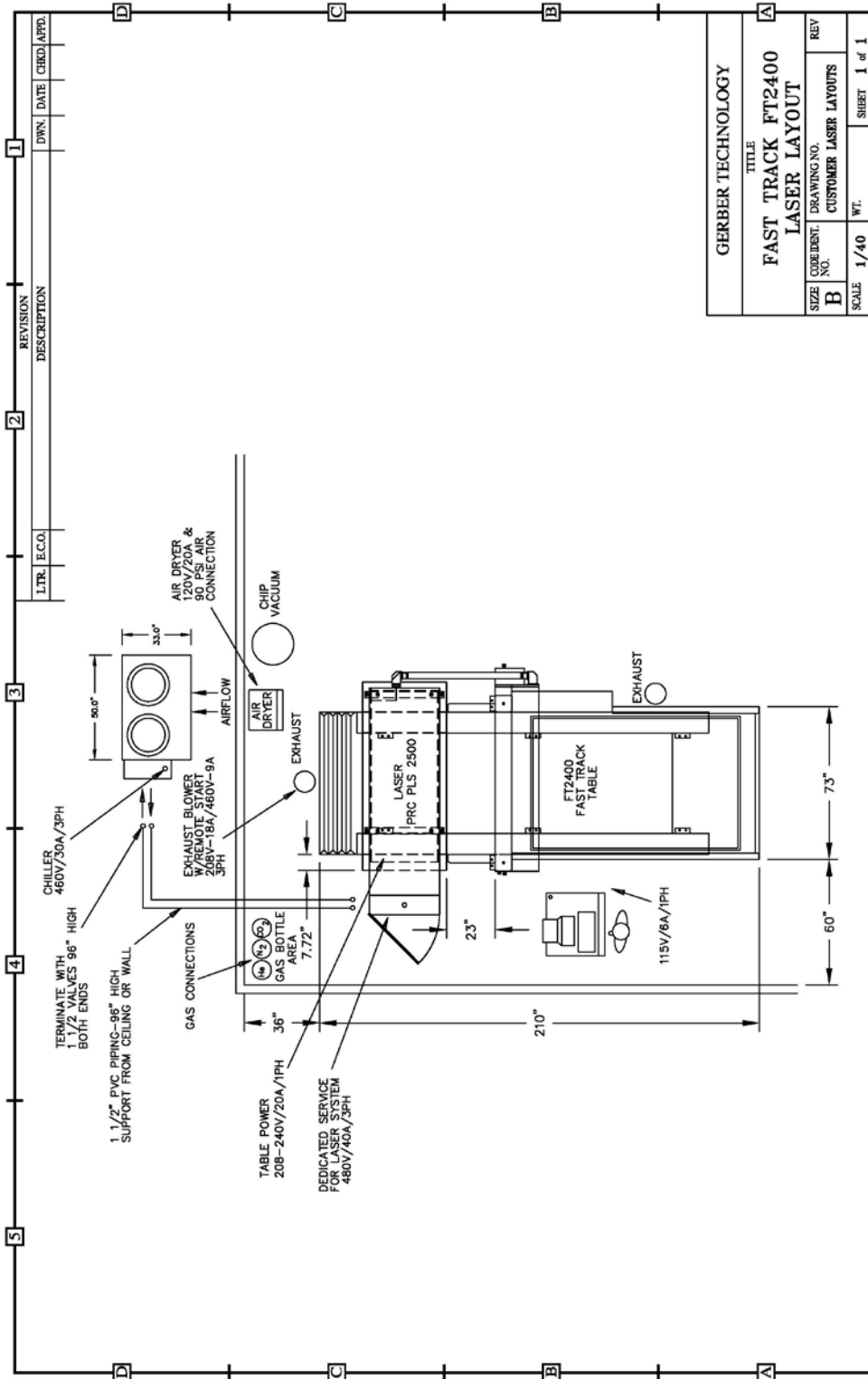

GERBER TECHNOLOGY	
TITLE FAST TRACK FT2400 LASER LAYOUT	
SIZE B	CODE/REV DRAWING NO. CUSTOMER LASER LAYOUTS
SCALE 1/40	WT. SHEET 1 of 1

Appendix B: Shipping Crates for FT1800

Description	Dimensions L x W x H	Weight
Table	190" x 90" x 44" (483 cm x 229 cm x 112 cm)	4500 lbs. (2041 kg)
Gantry	124" x 40" x 30" (315 cm x 102 cm x 76 cm)	1500 lbs. (680 kg)
PRC Laser	114" x 46" x 54" (290 cm x 117 cm x 137 cm)	2500 lbs. (1134 kg)
Rofin Laser	48" x 36" x 84" (power supply) (122 cm x 92 cm x 213 cm) 84" x 48" x 48" (resonator) (213 cm x 122 cm x 122 cm)	1200 lbs. 544 (kg) 1200 lbs. 544 (kg)
Chiller	72" x 45" x 80" (183 cm x 114 cm x 203 cm)	1200 lbs. (544 kg)
Laser Stand	86" x 46" x 42" (218 cm x 117 cm x 107 cm)	1000 lbs. (454 kg)
Exhaust	48" x 42" x 48" (122 cm x 107 cm x 122 cm)	500 lbs. (227 kg)
Accessory (only for PRC laser)	60" x 44" x 52" (152 cm x 112 cm x 132 cm)	500 lbs. (227 kg)

Appendix B: Shipping Crates for FT2400

Description	Dimensions L x W x H	Weight
Table	192" x 89" x 72" (488 cm x 226 cm x 183 cm)	7500 lbs. (3402 kg)
PRC Laser	114" x 46" x 54" (290 cm x 117 cm x 137 cm)	2500 lbs. (1134 kg)
Rofin Laser	48" x 36" x 84" (power supply) (122 cm x 92 cm x 213 cm) 84" x 48" x 48" (resonator) (213 cm x 122 cm x 122 cm)	1200 lbs. 544 (kg) 1200 lbs. 544 (kg)
Chiller	72" x 45" x 80" (183 cm x 114 cm x 203 cm)	1200 lbs. (544 kg)
Laser Stand	86" x 46" x 42" (218 cm x 117 cm x 107 cm)	1000 lbs. (454 kg)
Exhaust	48" x 42" x 48" (122 cm x 107 cm x 122 cm)	500 lbs. (227 kg)

Copyright Notice

COPYRIGHT© 2014 Gerber Innovations, Inc. All Rights Reserved.

This document may not be reproduced by any means, in whole or in part, without written permission of the copyright owner.

This document is furnished to support the **Gerber Innovations FT Series Laser**. In consideration of the furnishing of the information contained in this document, the party to whom it is given assumes its custody and control and agrees to the following:

The information herein contained is given in confidence, and any part thereof shall not be copied or reproduced without written consent of Gerber Innovations.

This document or the contents herein under no circumstances shall be used in the manufacture or reproduction of the article shown and the delivery of this document shall not constitute any right or license to do so.

Information in this document is subject to change without notice.

Printed in USA