

TITLE: Gerber Sabre™ 404 and 408 Installation Instructions

Gerber FastFact # 5002

Supplied by: Gerber Service

Last Modified: November 13, 2001

Summary: This document provides the installation and set-up process for the Sabre™ Series Routers. The Sabre™ should only be installed by factory-trained, distributor technicians. Under no circumstances should the Sabre™ be installed by the end-user.

Gerber Sabre™ 404 and 408 Installation Instructions



The Sabre™ is a precision machine that must be installed properly to ensure trouble-free operation. The Sabre™ should only be installed by factory-trained, distributor technicians. Under no circumstances should the Sabre™ be installed by the end-user. It is important to follow these steps carefully. Take particular care in lifting and moving the Sabre™. The unit can be damaged if handled in an abusive manner.

Please familiarize yourself with these procedures before each installation. It may be worthwhile to practice the process on your demonstration unit first. A smooth installation creates a long-lasting, positive impression on the customer.

If your customer does not have dock access, it is necessary to use a forklift (with extended forks) to remove the crated Sabre™ from the delivery truck. If your customer has dock access, it is possible to remove the unit from the truck with one or more pallet jacks. If your customer does not have either a forklift or a pallet jack, other arrangements should be made prior to delivery.

CAUTION: Gerber recommends that three people perform this installation.

Tools required

- Electric screw gun with a Phillips tip
- Phillips screwdriver
- Adjustable wrench
- 6 mm hex wrench
- 5 mm hex wrench
- 9/16" socket wrench
- Sabre™ roller casters (optional)
- AC voltmeter, 300 Vrms range

Disassembling the crate

Tool required: electric screw gun with a Phillips tip.

1. Remove the screws from the top of the crate, then remove the top.
2. Remove the screws securing the two cross supports that are exposed when the top is removed. Be sure to avoid dropping the cross support onto the machine while removing the screws.
3. Remove the screws from the remaining sides of the crate and remove the sidewalls.

Detaching the Sabre™ from the skid

Tools required: adjustable wrench, 9/16" socket wrench, and 6-mm hex wrench.

1. Remove the metal stringer (crosspiece) attached to rear legs.
2. Remove the electrical cabinet and all other boxes strapped to the skid under the router table.
3. Reattach the stringer and tighten the screws securely.
4. Remove the two lag screws that secure each leg plate to the skid with the 9/16" socket wrench.

Note: Do not remove the packing from around the router motor until the unit is in place.

The Sabre™ is now ready to be removed from the skid. A forklift is the best way to lift and move the Sabre™. If one is available, follow the instructions below. If one is not available, go to the instructions titled "Lifting and moving the Sabre™ without a forklift."

Lifting the Sabre™ from the skid with a forklift

Note: The Sabre™ can be lifted from either side. The Sabre™ 404 can also be lifted from the front and rear. Be sure that the forks reach all the way across the underneath of the machine. Never lift the Sabre™ higher than 12" off the floor.

1. Carefully position the forks under the sheet metal sidewalls, making sure that the machine is properly balanced. Lift the Sabre™ gently until it is several inches off the skid.

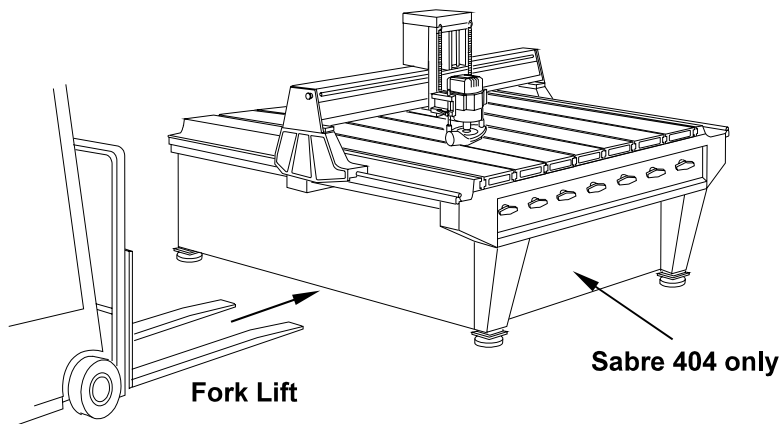

2. Slide the skid from under the machine.
3. Remove the plates from the bottom of the legs using the adjustable wrench.
4. Install the feet (located in the box on the top of the table). Turn them all the way up and tighten the locking nut.
5. Carefully transport the Sabre™ to the desired location in the shop with the forklift.

Lifting and moving the Sabre™ without a forklift

WARNING: This procedure must be done very carefully. Failure to follow the instructions can result in dropping and damaging the machine. Never crawl under the machine or place your hands or feet under the machine while it is being jacked up or is on supports.

Tools required: scissors jack capable of lifting 1000 pounds, two 4" x 4" x 8' timbers, 4 wood or cement blocks approximately 8" high, approximately 12 pieces of wood planking not thicker than 2", and four Sabre roller casters.

1. Place the scissors jack under the center of the front panel and carefully jack up the front of the machine so that the leg plates are 3 inches above the skid pads.
2. Insert a 4" x 4" between the machine and the skid from left to right. Position the 4" x 4" so that it is close to the front legs.
3. Put the blocks and planks on the floor under each end of the 4" x 4" timber. Make certain that the 4" x 4" is high enough so that the bottom of the 4" x 4" is higher than the top of the skid pad. If necessary, jack up the machine so that the 4" x 4" fits as shown below.

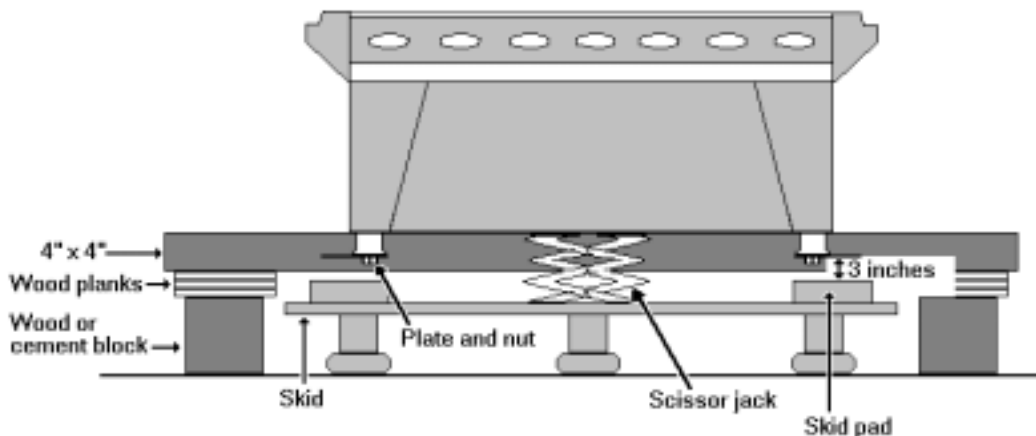

4. Lower the front of the machine so the sheet metal sidewalls rest on the 4" x 4", then remove the scissors jack.
5. Repeat steps 1 - 5 for the back of the machine.
6. Make certain that the machine is stable on the blocks, then remove the scissors jack and carefully slide the skid from underneath the Sabre™.
7. Remove the leg plates from the bottom of the four legs using the adjustable wrench.
8. Install the feet (located in the box on the top of the table). Turn them all the way up and tighten the locking nut.
9. Place the scissors jack under the center of the front panel and carefully jack up the front of the machine so that it is slightly above the 4" x 4".

WARNING: When performing steps 10 and 11, do not lower the machine more than 2" at a time. The machine could fall off the blocks and injure you and/or damage the machine.

10. Remove one 2" plank from each side, leaving the remaining planks and blocks in place. Lower the front no more than 2" onto the remaining planks & blocks.

11. Repeat steps 9 and 10 for the back of the machine.
12. Repeat the above process, alternating between the front and back of the machine, until the feet can be lowered onto the roller casters.
13. Lower the front of the machine so that the feet go into the roller casters. Repeat for the back of the machine.
14. Carefully roll the machine to its operating location.
15. Place the scissors jack under the center of the front panel and carefully jack up the front of the machine so that you can remove the roller casters, then lower the front feet to the floor.
16. Repeat step 15 for the back of the machine.

Stabilizing the Sabre™

Note: It is not essential that the Sabre™ is perfectly level to the floor, but it must be stable so that it doesn't rock from corner to corner.

1. Once the Sabre™ is in the operating location, place the scissors jack under the center of the front panel. If you are using a forklift or a pallet jack, be sure to use only one fork for this procedure.
2. Raise the jack (or fork) so that the front feet are just off the ground (no more than ½").
3. Adjust the two front feet so that they are firm against the floor, then tighten the locking nuts.
4. Slowly lower the jack.
5. Repeat for the back of the machine.

Unpacking the carriage

Tool required: adjustable wrench.

1. Remove the boxes secured to the top of the router table.
2. Remove the nuts and washer from the bolts that hold the packing in place around the carriage.
3. Carefully remove the packing.

Attaching the cables

Unpack the electrical cabinet and place it at the right rear of the system. All of the cabling is labeled and corresponds to the connectors on the electrical cabinet.

CAUTION: Be extremely careful to ensure that all cables are attached to the proper connectors. Failure to plug the cables into the correct connector can damage the machine.

Installing the keypad support stand

Tool required: 5-mm hex wrench.

Attach the keypad support stand to the right side of the system at the front with three 5-mm socket head screws (supplied). Be careful not to pinch any of the three cables running through it.

Plug the keypad connector into the connector on the underside of the stand and tighten the screws.

Connecting the T-Vac™

If the T-Vac™ option was ordered with the router, the manifold system was installed at the factory and on-site assembly is minimal. For either the 7 HP system or the 10 HP system, simply install the long 4" diameter PVC pipe by connecting one end behind the ball valves at the front of the system (under the table) and the other end to the T fitting with the 2" diameter side port. The Siemens® pressure relief valve is installed in the 2" opening using the 2" threaded adapter included in the kit. The threaded end screws into the bottom of the pressure relief valve and the other slides into the 2" opening on the T fitting. At the other end of the T fitting, insert the shorter straight section of PVC pipe. Connect this to the adapter (2 piece) threaded on the side port of the filter canister. An identical coupler is threaded on the end port of the canister, which connects to the intake port of the vacuum pump.

Note: Refer to the Sabre™ Pre-Installation Checklist for information on electrical requirements.

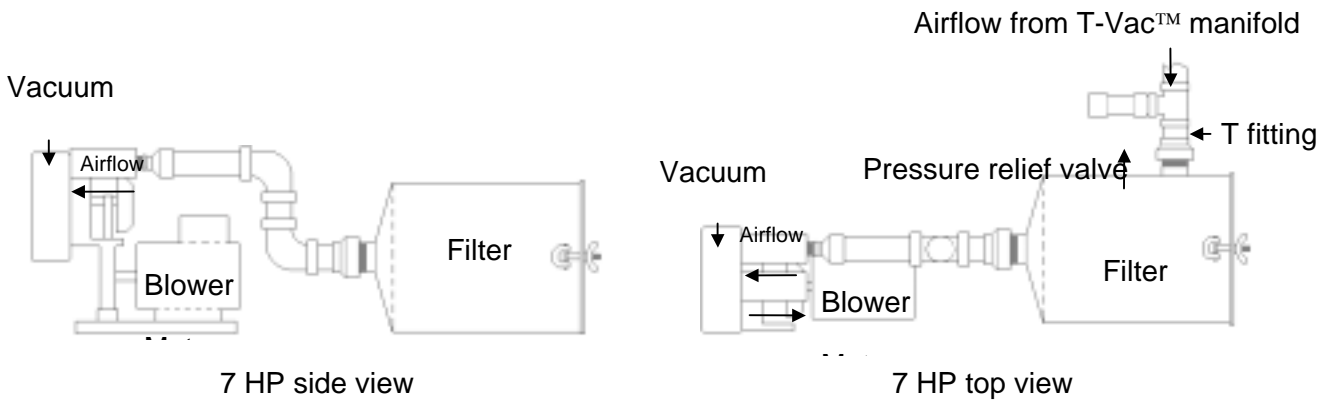

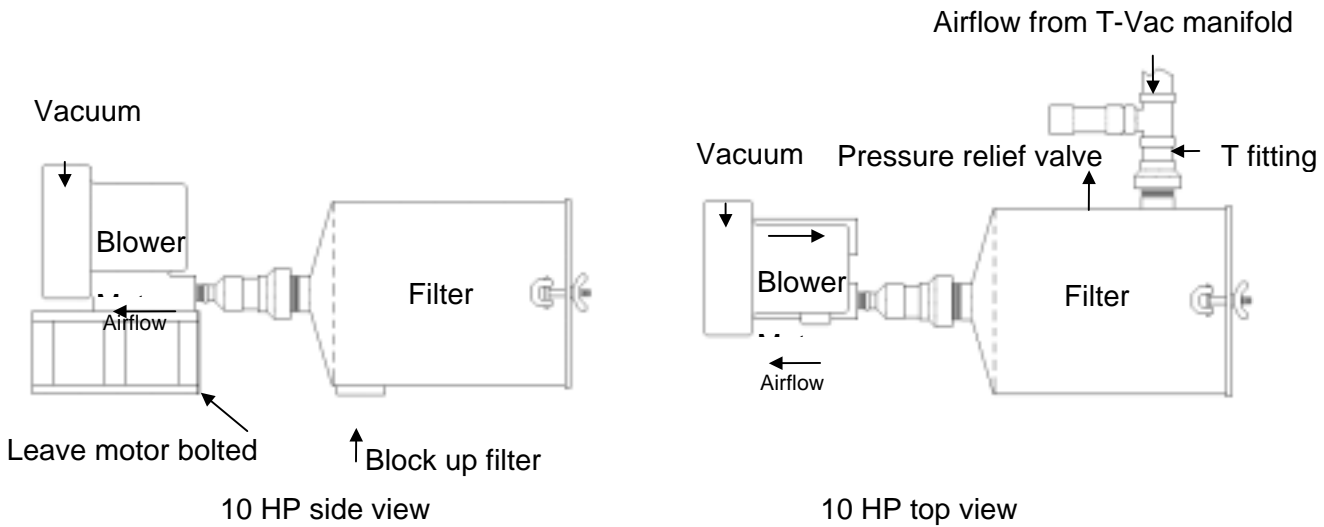

Speed controller installation

The speed controller for the optional High Frequency Spindle requires four cable connections.

CAUTION: Check the incoming power with a voltmeter before connecting. Refer to the Sabre Pre-Installation Checklist for more information on power and connector requirements.

1. Connect the thin black cable labeled P162 to the connector labeled R162 on the electrical cabinet.
2. Connect the motor cable labeled R760 to the plug labeled P760 under the router table. Tie wrap this cable to the P162 cable.
3. Connect the serial cable connector labeled R152 to the electrical cabinet connector labeled P152 and connect the other end to the speed controller.
4. Connect the power cable to the incoming power (230V +10% -15%, 3 phase, 30 Amp, or 460V +10% -15%, 3-phase, 20 Amp minimum).

Connecting incoming power to the Sabre™

Check the power to make sure the voltage is between 187V and 264V. This information is printed on the label located on the cabinet next to the power cord. If the incoming power is outside of that range **do not connect**. It will then be up to the customer to rectify the situation.

Connecting to the computer

The serial interface cable connects at the 25-pin connector located on the side of the electrical cabinet directly above the cable running to the keypad. Use only the cable that is supplied with the Sabre. It has special shielding which makes it more impervious to electrical noise.

Verifying that the circuit boards are completely seated

CAUTION: Static electricity is a serious threat to modern integrated circuits. Before reaching into the electrical cabinet or handling any components, touch any bare metal on the electrical cabinet chassis. This discharges any potentially harmful static electrical charge.

Occasionally, vibration during shipment may loosen the Uart and Duart circuit boards in the electrical cabinet. Before using the Sabre™, verify that the circuit boards are completely seated. Unplug the electrical cabinet power cord, then loosen the four screws (one at each corner) securing the electrical cabinet cover to the chassis. Remove the cover and push down firmly on the top of the Uart and Duart boards (shown at the right) to completely seat them in the Driver board connectors. Replace the cover on the electrical cabinet and secure it with the four screws.

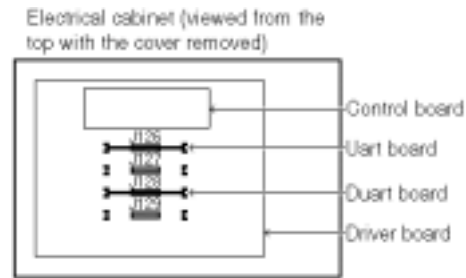

Before switching on the power

CAUTION: Do not plug in and turn on the router until you check the incoming power to verify that it is within the acceptable limits shown below. Failure to perform the necessary checks could result in major damage to the system.

Verify the following voltage levels at the receptacle for the electrical cabinet as shown in the illustrations below.

The Sabre™ requires an input voltage of 187 VAC – 264 VAC, single phase, 50/60 Hz. Determine the line voltage prior to installation. The receptacle must be near the Sabre™, and must be easily accessible. It must be wired by a licensed industrial electrician prior to installation. If there is no wall within six feet of the unit, a ceiling drop should be provided. The system is equipped with a 12-foot power cord.

Note: The Sabre™ reaches its maximum positioning rate at nominal line voltage of 230 VAC.

The electrical outlet receptacle (which you provide) must be installed prior to the installation of the Sabre™. **You MUST use the receptacle specified below.** DO NOT substitute another receptacle in its place. **Do not tie G and W together. The export (international) configuration does not use the W connection.** Contact your distributor if you are unsure of the configuration he ordered for you.

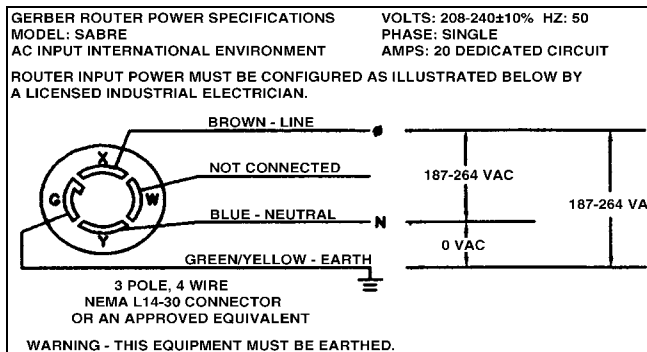
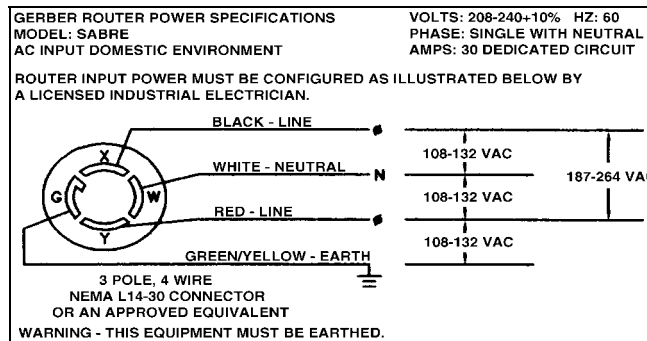

Before switching on the main power, recheck all the connections at the electrical cabinet to ensure that the cables are all plugged into the correct connectors. Specifically verify that:

- The keyboard connector is securely attached to the mating connector on the underside of the keyboard stand.
- The keyboard cable, labeled "P151 KEYBOARD," is securely attached to the electrical cabinet connector labeled "R151 KEYBOARD."
- The emergency stop cable, labeled "P166 EMERG STOP SWITCH," is securely attached to the electrical cabinet connector labeled "R166 EMERGENCY STOP."

CAUTION: Verify that there is no debris or hardware in the ways (indicated by the arrows in the illustration at the right). Debris will jam the router. Keep these areas clean and do not let routing chips build up here.

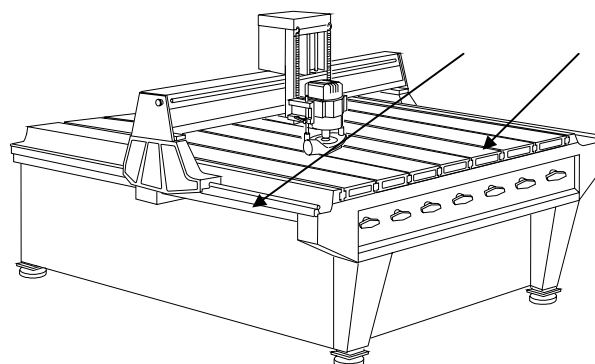

Milling the table mats

Prior to using the Sabre™, mill the mats so that they are absolutely flat. The mat milling operation uses a file in ART Path™. It takes approximately 30 minutes to mill a Sabre™ 404 table and approximately 60 minutes to mill a Sabre™ 408 table.

Before milling the mats, read and follow these safety guidelines:

WARNING: The Sabre™ is a high-speed cutting machine. Its use may be hazardous if you do not follow safety guidelines.

- Only a trained operator should run the equipment.
 - Wear protective eyewear, such as goggles or safety glasses, which covers the front and sides of your face.
 - Ear protection should be worn; the sound level at the operator control position may exceed 85 decibels.
 - Keep your fingers, hair, and clothing away from moving parts.
 - The Sabre™ moves quickly when routing. Do not lean over the machine. Stand in front of the router table during operation to provide easy access to the emergency stop switch.
 - Keep all persons at a safe distance from the machine when it is operating.
 - Keep the working area clear for easy access to the main power switch.
 - Unplug or turn off the router motor when changing tools.
1. Put the 1.250" table surfacing tool in the .5" collet and nut. Install the assembly in the router motor shaft, and tighten the nut.
 2. Initialize the tool from the tablemats using the procedure for initializing from the material surface. In this case, the mats are the material you are cutting.
 3. In ART Path, open the file 404MILL.RTP (for a Sabre™ 404) or file 408MILL.RTP (for a Sabre™ 408). Click on OK.
 4. Click on Output and Rout. When the Sabre™ receives the job, the keypad display shows:

STATUS

MACHINE: Idle

JOB: Ready

5. Set rpm to 16000.
6. Press START once. The display shows:

STATUS

MACHINE: Paused

JOB: Ready

Job Start, Load Material

7. Press START again. The display shows:

STATUS

MACHINE: Paused

JOB: Ready

Tool message

8. Press START again. The display shows:

STATUS

MACHINE: Active

JOB: Ready

Tool message

The motor turns on and the router plunges quickly to its initialized height, then plunges into the mat material and begins cutting.